

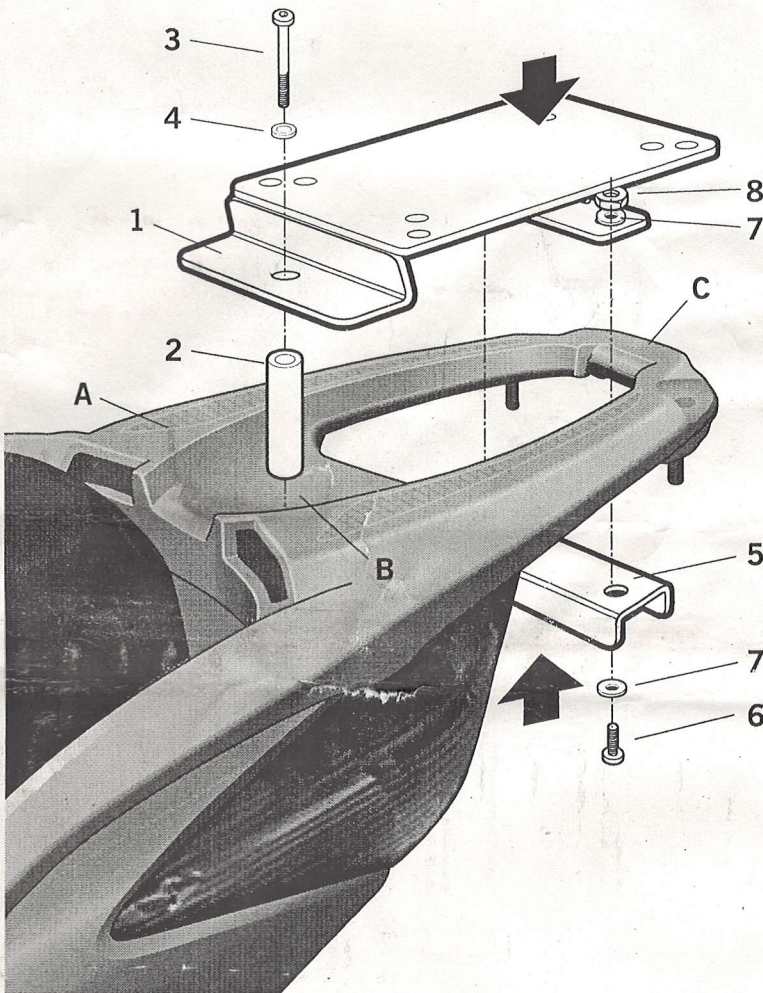







- (E)** Consejo para un correcto montaje del kit: No apretar los tornillos del todo hasta asegurarse que el KIT está correctamente colocado y alineado.
- (GB)** Advice for correct fitting of the kit: Do not fully tighten the screws until it is ensured that the KIT is correctly attached and aligned.
- (F)** Conseil pour un montage correct du kit: Ne pas serrer les vis avant d'être sûr que le KIT est correctement monté et ajusté.
- (D)** Hinweis für einen korrekten Einbau des Bausatzes: Ziehen Sie die Schrauben nicht ganz fest, bevor Sie sich nicht vergewissert haben, daß der Bausatz korrekt eingestellt und ausgerichtet ist.
- (I)** Consiglio per un montaggio corretto del kit: Non stringere del tutto le viti fin tanto non si è sicuri che il kit è collocato correttamente e allineato.



- (E)** Montar el soporte KIT TOP (1) sobre el transportin original (A) de la moto y fijarlo en zona (B) mediante el distanciador (2), el tornillo (3) y la arandela (4). Y en zona (C) mediante la chapa brida (5), los tornillos (6), las arandelas (7), y las tuercas (8).
- (GB)** Assemble the KIT TOP support (1) on the original fold-back seat (A) of the motorcycle and fix it in area (B) using the distance piece (2), the screw (3) and the washer (4). And in area (C) using the flange (5), the screws (6), the washers (7), and the nuts (8).
- (F)** Monter le support KIT TOP (1) sur le siège arrière originel (A) de la moto et le fixer dans la zone (B) avec l'entretoise (2), la vis (3) et la rondelle (4). Et dans la zone (C) avec la plaque bride (5), les vis (6), les rondelles (7), et les écrous (8).
- (D)** Die Halterung KIT TOP (1) auf den Originalgepäckträger (A) des Motorrads montieren und in der Zone (B) mittels Abstandsscheibe (2), Schraube (3) und Scheibe (4) fixieren. Und in Zone (C) mittels Flanschblech (5), Schrauben (6), Scheiben (7), und Muttern (8).
- (I)** Montare il supporto KIT TOP (1) nel sedile posteriore (A) della moto e fissarlo nella zona (B) con il distanziatore (2), la vite (3) e la rondella (4). E nella zona (C) con la placca briglia (5), le viti (6), le rondelle (7), ed i dadi (8).

**COMPONENTES / PARTS / COMPOSANTES / EINZELBAUTEILE / COMPONENTI:**

Pos.	Ref.	Cant.	
1	260462	1	 KIT TOPMASTER
2	260461	1	 Distanciador Ø16 Ø11 X 43 - Spacer - Entre-toise - Abstandshalter - Distanziatore
3	304095	1	 Tornillo M8 x 75 DIN 912 - Screw - Vis - Schraube - Vite
4	303020	1	 Arandela Ø8 - Washer - Rondelle - Scheibe - Rondella
5	260463	1	 Chapa brida - Cover flange - Plaque bride - Flansch-Blech - Placca briglia
6	304037	2	 Tornillo M6 x 35 DIN 912 - Screw - Vis - Schraube - Vite
7	303017	4	 Arandela especial Ø16-Ø6 - Washer - Rondelle - Scheibe - Rondella
8	302021	2	 Tuerca M6 autoblocante - Self-blocking Nut M6 - Écrou M6 autobloquant - Selbstanziehende Mutter M6 - Bullone M6 autobloccante

**HONDA SH125 / 150 / 250 SCOOPY 05**  
HOSH15ST  
**KIT TOPMASTER**



**SHAD**

REF. 500479  
Edición 1ª